

Vibe Basin Mixer

Finish & SKU

Chrome
 NR200701CH



Specifications

Watermark License

WM-060073

Temperature Rating

Min 1°C-Max 75°C

Pressure Rating

Min 150kpa-Max 500kpa

Warranty



Features

- 25mm ceramic disc cartridge can be adjusted to reduce water temperature and flow control settings, saving energy
- Solid brass construction for longevity
- Solid easy-to-grip modular handle
- NEOPERL aerator with slim stream flow director
- Twin-stud mounting for secure basin installation
- PEX flexible hoses-/BSP female Suitable for mains pressure installation

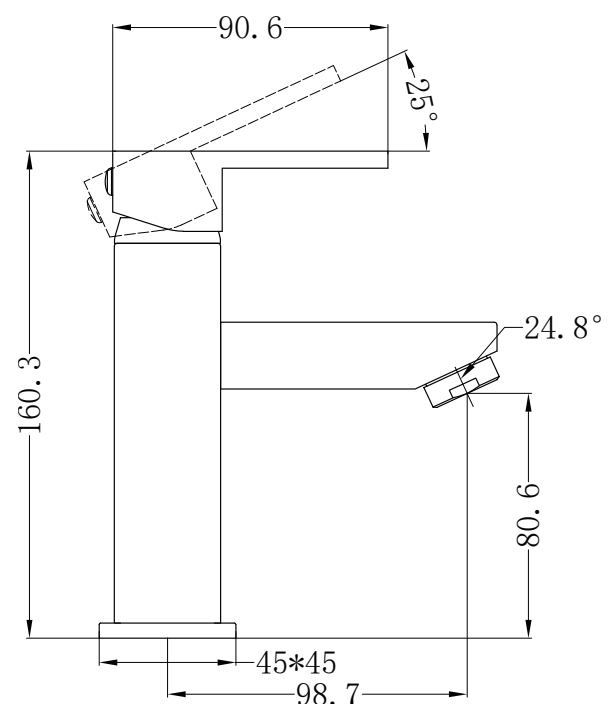

Maintenance And Care

- Regularly check the mixer and connections for signs of wear or leaks.
- Clean the tap with mild soapy water to maintain its appearance, avoiding harsh chemicals and abrasive materials that may damage the finish.

- Dimensions are nominal measurements only.